

W.450PNA | 50 TONS HYDRO-PNEUMATIC PRESSE

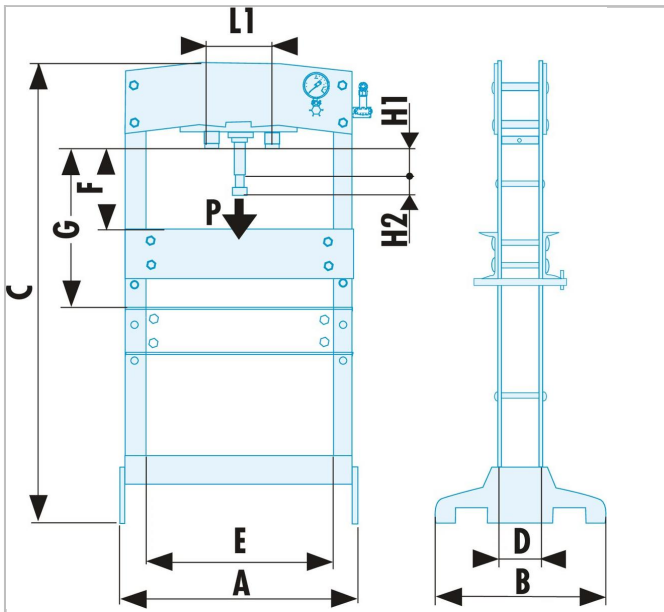

Description:

- Lateral moving jack.
- Integral pusher support + pushers included.
- Supplied with pair of Vees.
- Quick approach with the handle and the foot pedal.
- Winch
- Strong and stable construction.
- Floor anchoring possible.
- Eye level pressure gauge for a better visibility.



	W.450PNA
A [mm]	1180.0