

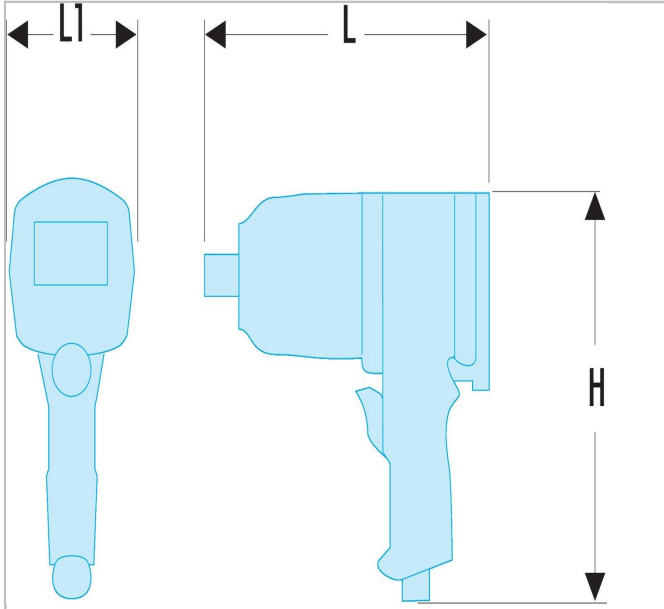

## NM.3030F | 1" straight impact wrench - short anvil - high performance



### Description:

- Dual hammer mechanism for tool durability.
- 2 stage trigger for improved control.
- One hand forward reverse switch with two settings in both directions.
- Rubber over molded grip insulating against cold and vibrations.
- Rubber bumper protecting the motor housing.
- 360° adjustable handle for improved comfort.
- Safe: Dual socket retainer: ring retainer hole to use a safety pin.
- Exhaust blows air away from the operator for comfort of use.



	NM.3030F
Height H [mm]	97.0
Length L [mm]	346.0
Length L1 [mm]	101.0
Torque NM. [Nm]	3390.0
Vibration Level [m/s <sup>2</sup> ]	14,75 (K=1,96)
Maximum Speed [rpm]	5000.0
Weight [Kg]	8.0