

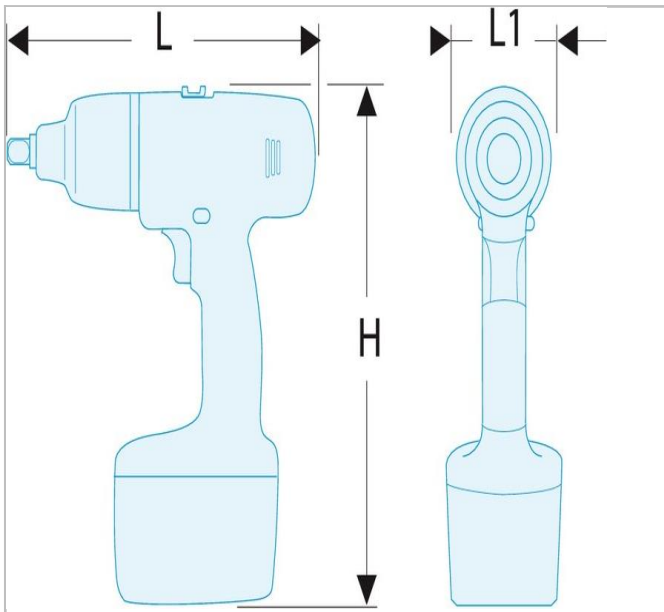

CL3.P18SD2 | 18V 13mm Drill/Driver 2.0Ah Kit



Description:

- Sufficient power for heavier tasks in a compact package.
- 14 torque settings for consistent screw driving into a variety of materials.
- Two speed all metal gearbox for improved durability.
- Protection bumpers built into the casing.
- Supplied in a ToughSystem® kitbox with 2x2.0Ah batteries and a charger.



	CL3.P18SD2
Height H [mm]	218.0
Length L [mm]	190.0
Length L1 [mm]	80.0
Torque NM. [Nm]	60.0
Vibration Level [m/s ²]	3 (K=1,5)
Maximum Speed [rpm]	2000.0
Weight [Kg]	7.4